

## Solar Panel Dump Radiators

Our range of Solar Panel Dump Radiators are designed to dissipate excess heat from solar panel installations at times of low or no demand that would otherwise cause the system temperature to rise leading to potential equipment failure due to over heating.

We have a standard range of coolers from 5 kW to 45 kW comprising of a Finned Tube Coil, single phase 240v air fan and a fan motor control/switching panel that turns the fan on and off determined by temperatures set on the controller.

### Design Basis

Each radiator is designed to cool 40% ethylene glycol/water solution from 80°C to 60°C with air at 32°C maximum.

### Finned Tube Coil

- Copper Tubes
- Aluminium Fins
- Galvanised Steel Casing

### Fan Complete with Electric Motor

- Aluminium Impeller
- Single phase 240 V motor—IP55 weatherproof rating
- Class F Insulation

### Fan Motor Control/Switching Panel

- IP65 painted steel enclosure
- Hinged door and removable gland plate and mechanically interlocked isolator switch
- Hand/Off/Auto fan selector switch
- Temperature controller with digital readout to set fan run and stop temperatures
- Running and overload tripped LED indicating lamps

### Additional Options

- Strap-on pipe temperature sensor
- PT100 temperature sensor in pocket
- BMS power on/off input
- BMS system running output signal
- BMS fault signal
- Emergency stop switch



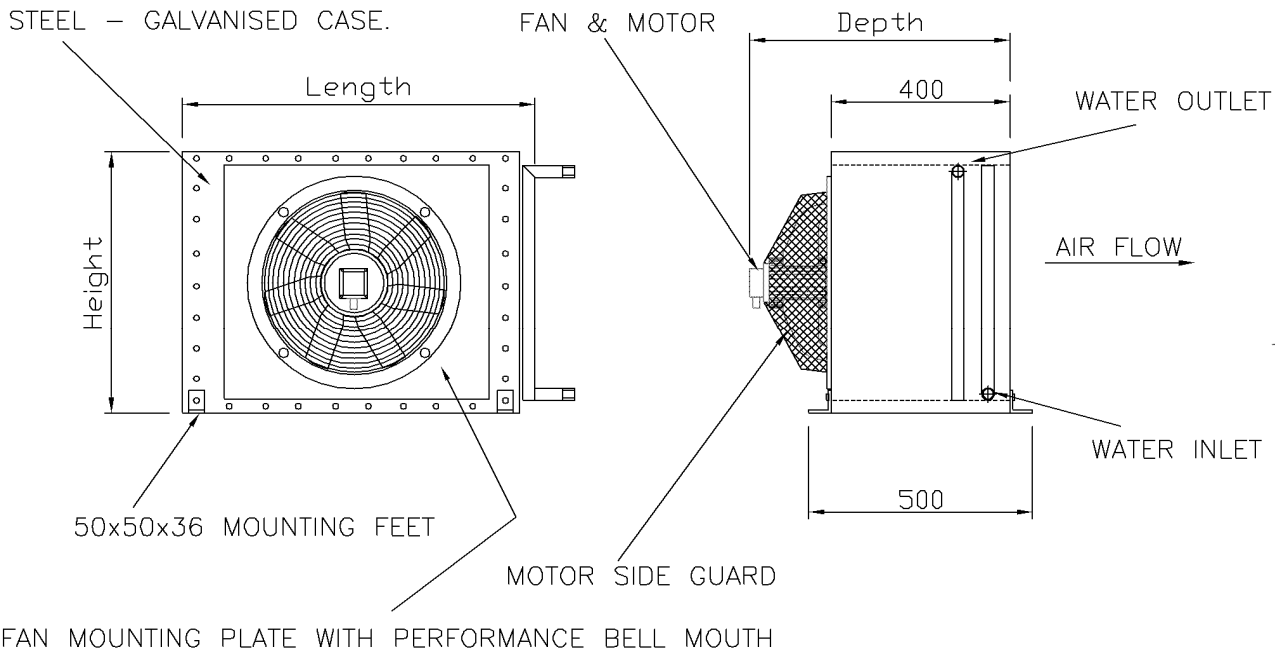

<u>Output (kW)</u>	<u>Weight (kg)</u>	<u>Length (mm)</u>	<u>Depth (mm)</u>	<u>Height (mm)</u>
5	25	490	470	420
10	30	680	595	600
15	35	705	585	600
20	55	855	585	660
25	61	885	605	660
30	70	965	605	660
45	78	1005	605	900

## Other Products from UK Exchangers Ltd

As well as Solar Dump Radiators we offer a comprehensive range of heat exchangers, designed to meet the a wide range of applications:

- Air to Air Plate Heat Exchangers
- Thermal Wheels
- Finned Tube Coils
- Brazed Plate Heat Exchangers
- Gasketed Plate Heat Exchangers
- Water to Water Packaged Systems
- Steam to Water Packaged Systems
- All Welded Plate Heat Exchangers
- Heat Transfer Panels



**UK Exchangers Ltd**  
Unit 55, Stilebrook Road  
Olney, Buckinghamshire MK46 5EA  
Tel: 01234-244320  
Fax: 01234-714976  
E-Mail: [sales@ukeltd.com](mailto:sales@ukeltd.com)  
Web Site: [www.uk-exchangers.com](http://www.uk-exchangers.com)